

Prosilica GE

4000



- 11 Megapixel camera
- ON Semi KAI-11002 sensor
- Galvanically isolated I/O
- Various lens mount options

For speed and good sensitivity

Compact, high performance CCD machine vision cameras with GigE Vision

Prosilica GE 4000 with ON Semi KAI-11002 runs 5.0 frames per second at 10.7 MP resolution.

Prosilica GE cameras are very compact, high-performance machine vision cameras with Gigabit Ethernet interface (GigE Vision®).

The GigE interface allows for very fast frame rates and long cable lengths.

- Compact size
- VGA to 16 Megapixel resolution
- Fast frame rates to 205 fps
- OnSemi KAI CCD sensors
- Modular options available

Specifications

Interface	IEEE 802.3 1000baseT
Resolution	4008 (H) × 2672 (V)
Sensor	ON Semi KAI-11002
Sensor type	CCD Progressive
Sensor size	Type 35 mm
Pixel size	9 μm × 9 μm
Lens mount (default)	F-Mount
Max. frame rate at full resolution	5 fps
ADC	12 Bit
Image buffer (RAM)	32 MByte

Output

Bit depth	8-bit or 12-bit
Monochrome pixel formats	Mono8, Mono12, Mono12Packed
Raw pixel formats	BayerGR8, BayerGR12, BayerGR12Packed

General purpose inputs/outputs (GPIOs)

TTL I/Os	1 input, 3 outputs (with galvanic isolation)
RS232	1

Operating conditions/dimensions

Operating temperature	0 °C to +50 °C ambient (without condensation)
Power requirements (DC)	5 to 24 VDC
Power consumption	6 W at 12 VDC
Mass	402 g
Body dimensions (L × W × H in mm)	110 × 66 × 66 (including connectors)

Quantum efficiency

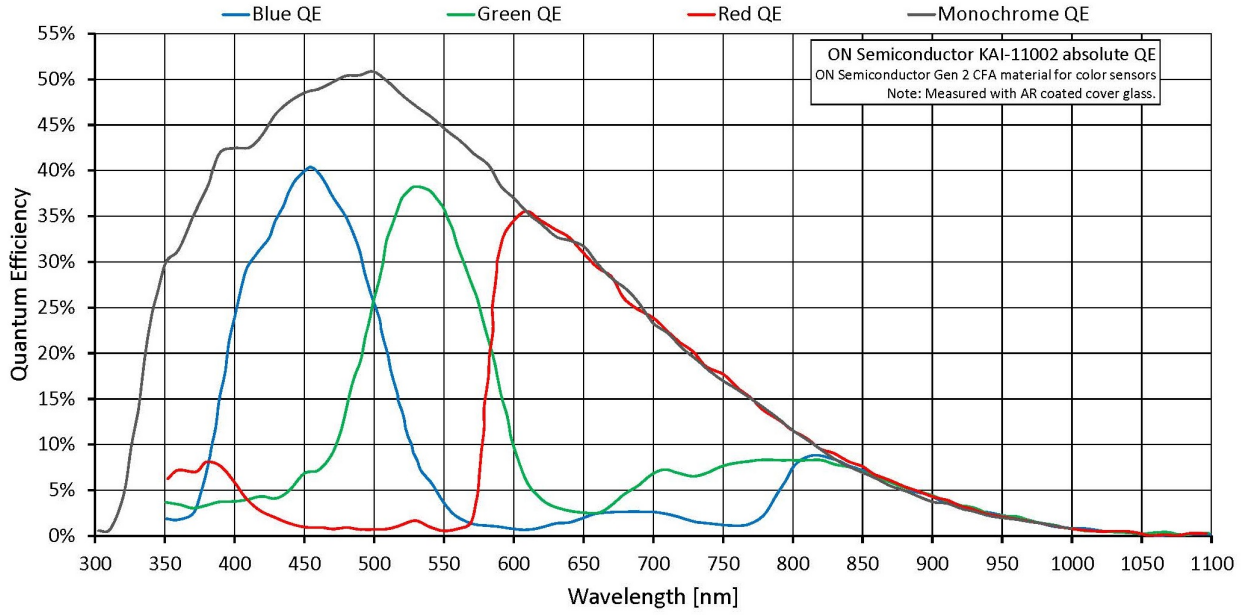

Features

Prosilica GE4000 features include:

- Defect masking for columns
- Region of interest (ROI), DSP subregion (selectable ROI for auto features)
- Binning (Sum)
- Auto gain (manual gain control: 0 to 34 dB)
- Auto exposure (manual exposure controls: 140 μ s to 68.7 s)
- Auto white balance
- StreamBytesPerSecond (bandwidth control)
- Stream hold
- Sync out modes: Trigger ready, input, exposing, readout, imaging, strobe, GPO
- Global shutter (digital shutter)
- Recorder and Multiframe acquisition modes
- Event channel
- Image chunk data
- Storable user sets

Technical drawing

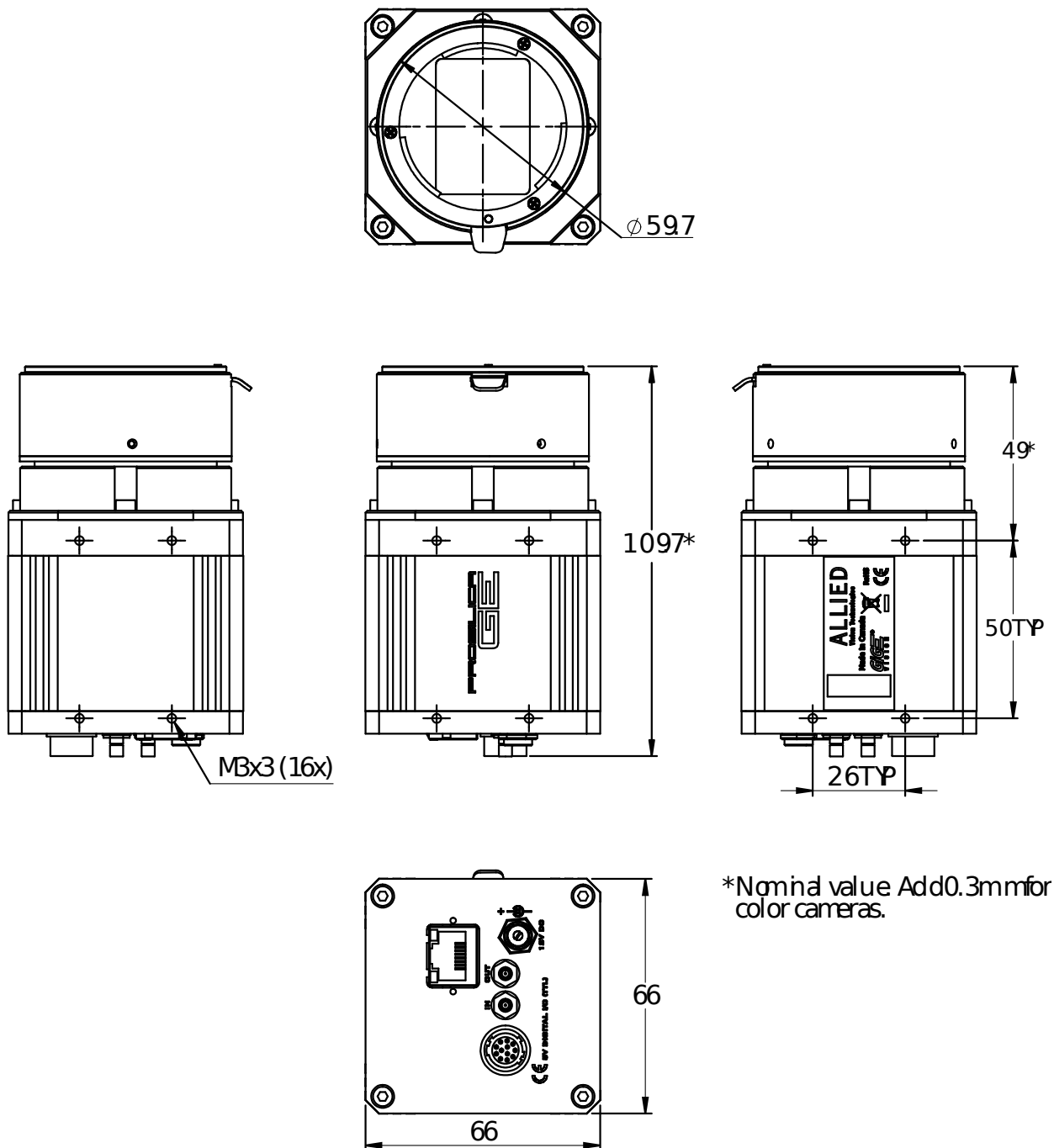

Applications

Prosilica GE4000 is ideal for a wide range of applications including:

- LCD panel inspection
- Semiconductor wafer inspection

- Solar panel inspection
- Aerial photography
- 3D metrology
- General machine vision
- Public security
- Surveillance
- Traffic imaging (Intelligent Traffic Systems)
- Embedded systems
- OEM applications