

Prosilica GT

2050NIR



- -20° C to +65° C (ambient temperature)
- NIR enhanced sensor
- PoE
- IEEE 1588 PTP
- Trigger over Ethernet
- Auto iris

Engineered for every environment

High-resolution cameras for demanding applications

Prosilica GT 2050NIR with CMOSIS/ams CMV4000 NIR runs 28.6 frames per second at 4.2 MP resolution.

The rugged housing optimized for heat dissipation makes Prosilica GT the ideal solution for harsh environments. The various lens control options allow constant adjustment of the image brightness to changing light conditions. Offering resolutions of up to 31 megapixels, they are ideal for high-definition imaging applications with demanding requirements of robustness and design-in flexibility.

Easy software integration with Allied Vision's [Vimba Suite](#) and compatibility to the most popular [third party image-processing libraries](#).

See the [Modular Concept](#) for lens mount, housing variants, optical filters, case design, and other modular options. See the [Customization and OEM Solutions](#) webpage for additional options.

Specifications

Interface	IEEE 802.3 1000BASE-T, IEEE 802.3af (PoE)
Resolution	2048 (H) × 2048 (V)
Sensor	CMOSIS/ams CMV4000 NIR
Sensor type	CMOS
Shutter mode	GS (Global shutter)
Sensor size	Type 1
Pixel size	5.5 μm × 5.5 μm
Lens mounts (available)	C-Mount, CS-Mount, F-Mount, M42-Mount
Max. frame rate at full resolution	28.6 fps
ADC	12 Bit
Image buffer (RAM)	128 MByte

Imaging performance

Imaging performance data is based on the evaluation methods in the EMVA 1288 Release 3.1 standard for characterization of image sensors and cameras. Measurements are typical values for NIR models measured at full resolution without optical filter.

Quantum efficiency at 529 nm	79 %
Quantum efficiency at 850 nm	42 %
Temporal dark noise	13.0 e ⁻
Saturation capacity	9200 e ⁻
Dynamic range	56.7 dB
Absolute sensitivity threshold	13.5 e ⁻

Output

Bit depth	8-bit or 12-bit
Monochrome pixel formats	Mono8, Mono12, Mono12Packed

General purpose inputs/outputs (GPIOs)

TTL I/Os	1 input, 2 outputs
Opto-isolated I/Os	1 input, 2 outputs
RS232	1

Operating conditions/dimensions

Operating temperature -20 °C to +65 °C ambient (without condensation)

Power requirements (DC) 7 to 25 VDC AUX or 802.3at Type 1 PoE

Power consumption 3.5 W at 12 VDC; 4.3 W PoE

Mass 210 g

Body dimensions (L × W × H in mm) 86 × 53.3 × 33 (including connectors)

Quantum efficiency

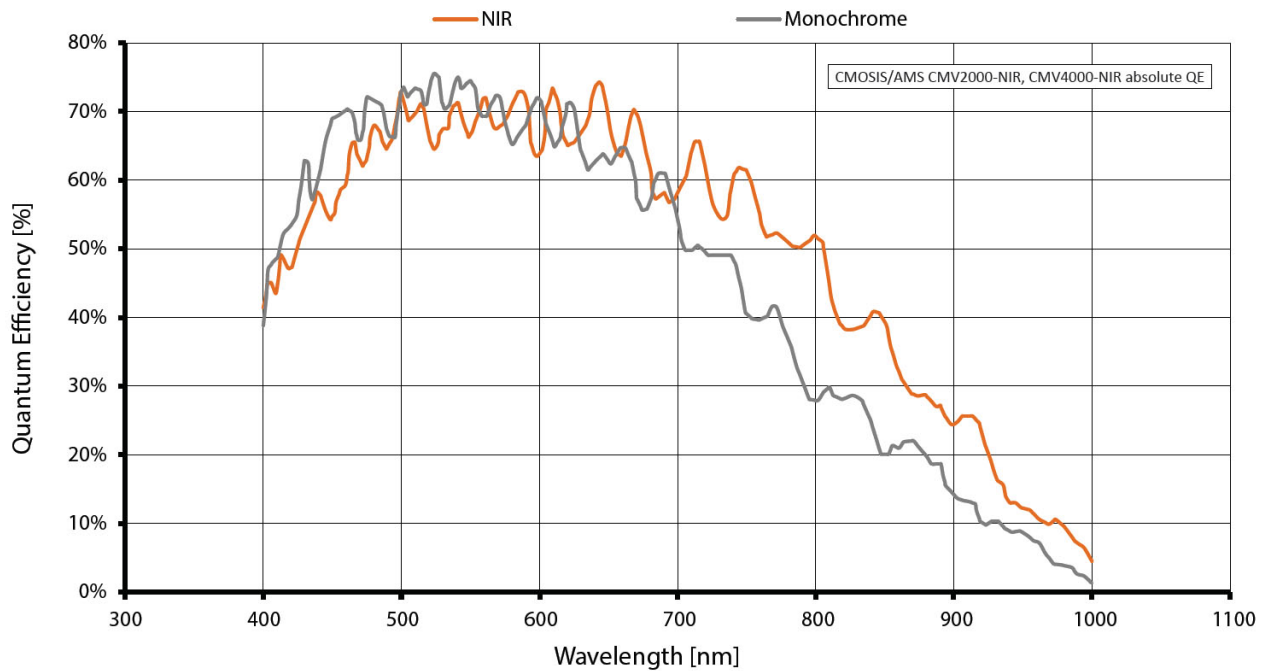

Features

Image control: Auto

- Auto exposure
- Auto gain

Image control: Other

- Black level
- Decimation
- DPC (defect pixel correction)
- Gamma
- HDR mode
- LUT (look-up table)
- Reverse X/Y
- ROI (region of interest)

Camera control

- Acquisition frame rate
- Auto iris
- Bandwidth control
- Event channel
- Firmware update in the field
- I/O and trigger control
- Image chunk data
- PTP (IEEE 1588 Precision Time Protocol)
- Stream hold
- Temperature monitoring
- ToE (trigger over Ethernet, action commands)
- User sets

Technical drawing

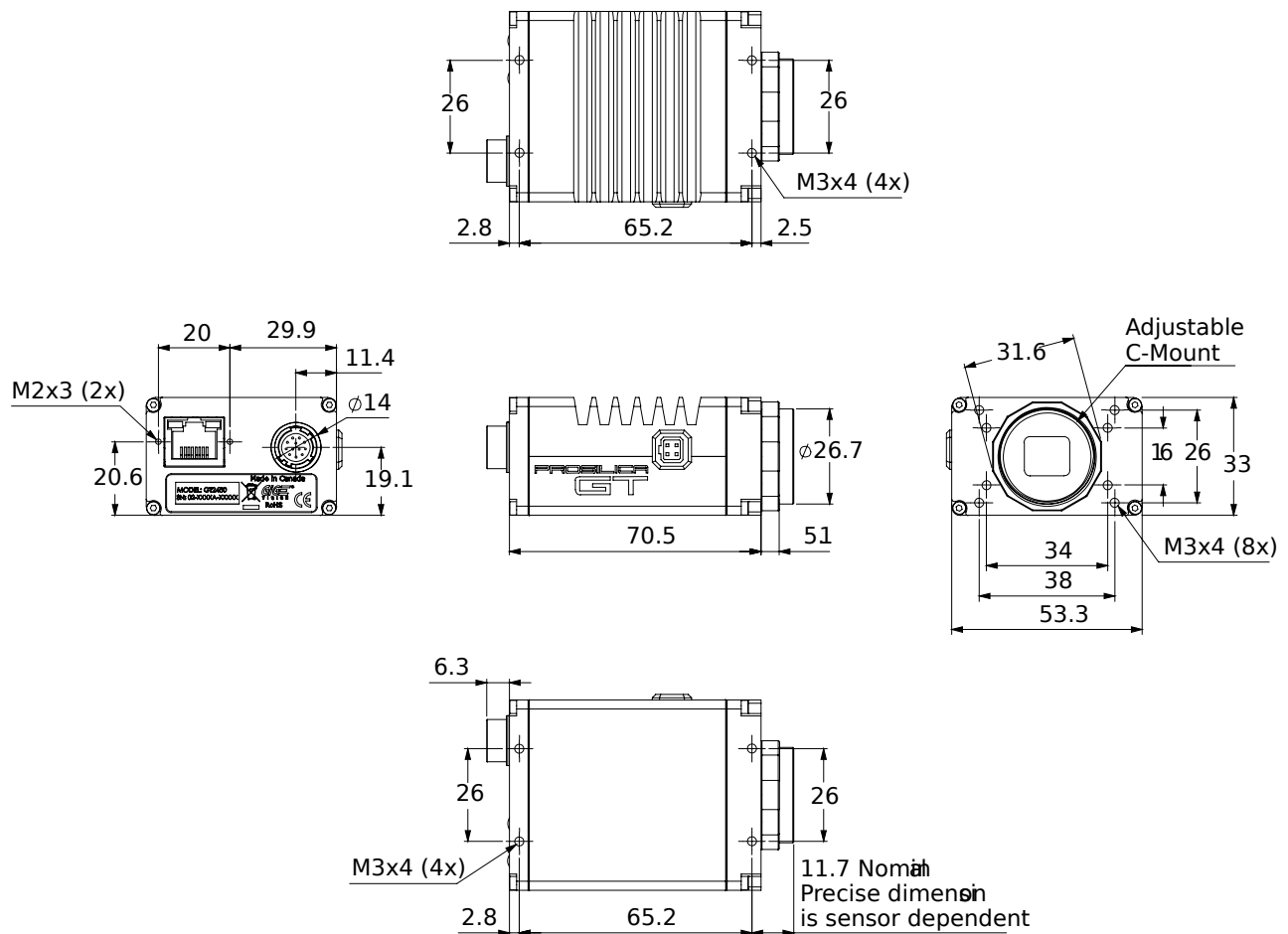

Applications

Prosilica GT2050NIR is ideal for a wide range of applications including:

- Outdoor imaging
- Traffic imaging and Intelligent Traffic Systems
- Public security and surveillance
- Industrial inspection
- Machine vision
- Microscopy
- Medical and healthcare