

Prosilica GX

2750



- 240 MBps with dual interface LAG technology
- 3-axis motorized lens control
- 20 fps at full resolution
- Sony ICX694 sensor

Shift up to double speed

The fastest Gigabit Ethernet cameras in the world -
240MB/s

Prosilica GX 2750 with Sony ICX694 runs 20.0 frames per second at 6.1 MP resolution.

Prosilica GX cameras are fast, compact machine vision cameras with Gigabit Ethernet interface (GigE Vision®). The GX-Series have two screw-captivated Gigabit Ethernet ports configured as a Link Aggregation Group (LAG) to provide a sustained maximum data rate of 240 MBytes per second. Prosilica GX can also work at half the bandwidth (120 MB/s) using a single cable.

- Very Fast - 240 MB/s
- 3-axis motorized lens control and video-type autoiris
- Single or dual Ethernet port operation
- 1 to 29 Megapixel
- Fast frame rates upto 112 fps
- OnSemi KAI or Sony quad-tap CCD sensors
- Modular options available

Specifications

Interface	IEEE 802.3 1000baseT
Resolution	2750 (H) × 2200 (V)
Sensor	Sony ICX694
Sensor type	CCD Progressive
Shutter mode	GS (Global shutter)
Sensor size	Type 1
Pixel size	4.54 μm × 4.54 μm
Lens mount (default)	C-Mount
Max. frame rate at full resolution	20 fps
ADC	14 Bit
Image buffer (RAM)	128 MByte

Output

Bit depth	14-bit (monochrome); 12-bit (color)
Monochrome pixel formats	Mono8, Mono12, Mono12Packed, Mono14
RGB color pixel formats	RGB8Packed, BGR8Packed, RGBA8Packed, BGRA8Packed
Raw pixel formats	BayerRG8, BayerRG12, BayerGR12Packed

General purpose inputs/outputs (GPIOs)

Opto-isolated I/Os	2 inputs, 4 outputs
RS232	1

Operating conditions/dimensions

Operating temperature	0 °C to +50 °C ambient (without condensation)
Power requirements (DC)	10 to 24 VDC
Power consumption	6.1 W at 12 VDC (Single GigE Mode); 7.1 W at 12 VDC (Dual GigE Mode)
Mass	264 g
Body dimensions (L × W × H in mm)	108.1 × 53.3 × 33 (including connectors)

Quantum efficiency

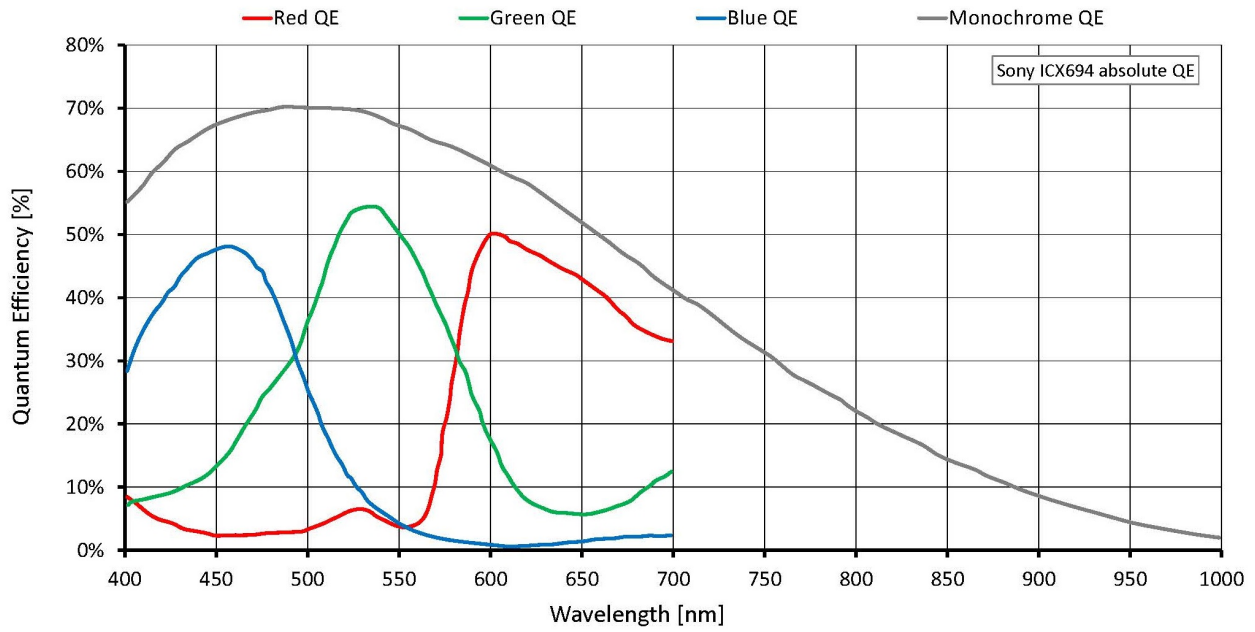

Features

Prosilica GX2750 features include:

- 3-axis motorized lens control
- Video-type auto iris
- Region of interest (ROI), DSP subregion (selectable ROI for auto features)
- Binning (Sum)
- Auto gain (manual gain control: 0 to 33 dB)
- Auto exposure (manual exposure controls: 10 μ s to 26.8 s)
- Auto white balance
- StreamBytesPerSecond (bandwidth control)
- Stream hold
- Sync out modes: Trigger ready, input, exposing, readout, imaging, strobe, GPO
- Global shutter (digital shutter)
- Recorder and Multiframe acquisition modes
- Event channel
- Chunk data
- Storable user sets

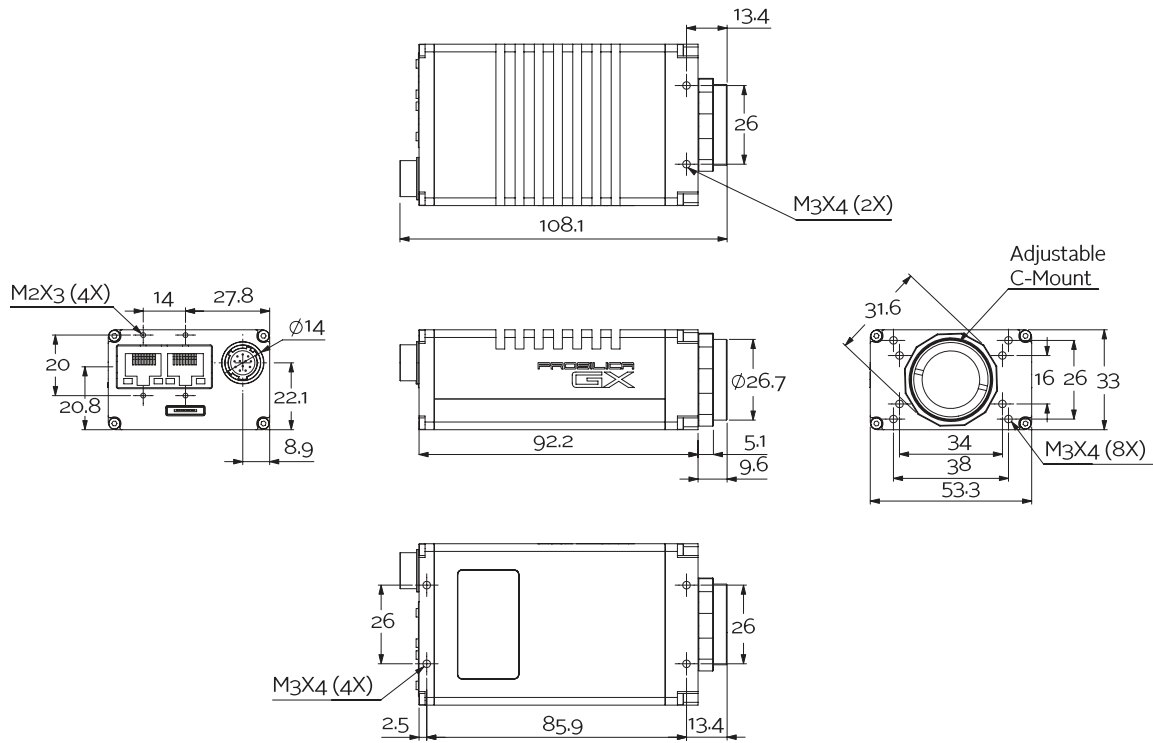

Prosilica GX2750 is ideal for a wide range of applications including:

- Industrial inspection
- Machine vision
- LCD panel inspection
- Medical imaging
- Ophthalmology
- Aeronautical and aerospace
- Public security
- Surveillance
- Traffic imaging
- OEM applications
- Other machine vision applications