

Prosilica GE

1650



- 32 fps @ full resolution
- ON Semi KAI-2020 sensor
- Galvanically isolated I/O
- Various lens mount options

For speed and good sensitivity

Compact, high performance CCD machine vision cameras with GigE Vision

Prosilica GE 1650 搭载 ON Semi KAI-2020 传感器，在 1.9 MP 分辨率下速度可达 32.0 帧/秒。

Prosilica GE cameras are very compact, high-performance machine vision cameras with Gigabit Ethernet interface (GigE Vision®).

The GigE interface allows for very fast frame rates and long cable lengths.

- Compact size
- VGA to 16 Megapixel resolution
- Fast frame rates to 205 fps
- OnSemi KAI CCD sensors
- Modular options available

性能参数

接口	IEEE 802.3 1000baseT
分辨率	1600 (H) × 1200 (V)
传感器	ON Semi KAI-2020
传感器类型	CCD Progressive
传感器尺寸	Type 1
像元尺寸	7.4 μm × 7.4 μm
标准镜头接口	C-Mount
最大满帧帧率	32 fps
ADC	12 Bit
缓存 (RAM)	32 MByte

输出

Bit 位数	8-bit or 12-bit
黑白像素格式	Mono8, Mono12, Mono12Packed
YUV 彩色像素格式	YUV411Packed
RGB 彩色像素格式	RGB8Packed, BGR8Packed, RGBA8Packed, BGRA8Packed, RGB12Packed
原始像素格式	BayerGR8, BayerGR12, BayerGR12Packed

通用输入输出口 (GPIOs)

TTL I/Os	1 input, 3 outputs (with galvanic isolation)
RS232	1

工作条件/尺寸

工作温度	0 °C to +50 °C ambient (without condensation)
电源要求 (DC)	5 to 24 VDC
功耗	5 W at 12 VDC
重量	169 g
尺寸 (L × W × H in mm)	80 × 51 × 39 (including connectors)

量子转换效率

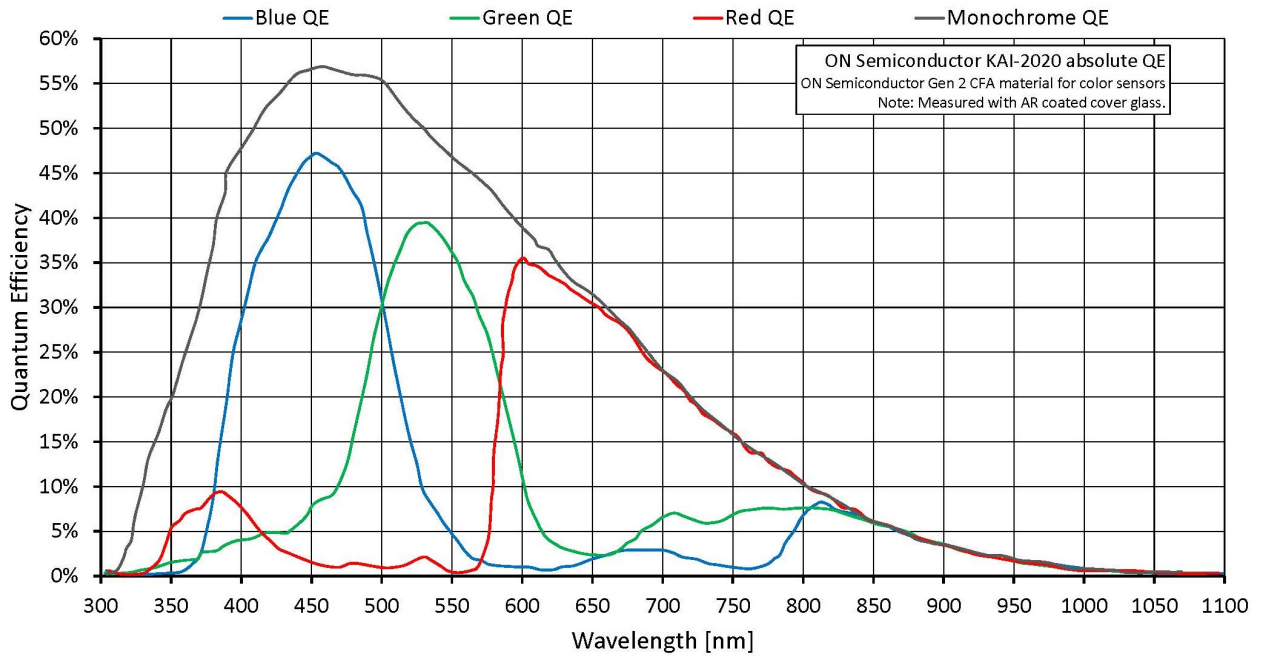

特性

Prosilica GE1650 features include:

- Region of interest (ROI), DSP subregion (selectable ROI for auto features)
- Binning (Sum)
- Auto gain (manual gain control: 0 to 34 dB)
- Auto exposure (manual exposure controls: 50 μ s to 53.7 s)
- Auto white balance
- StreamBytesPerSecond (bandwidth control)
- Stream hold
- Sync out modes: Trigger ready, input, exposing, readout, imaging, strobe, GPO
- Global shutter (digital shutter)
- Recorder and Multiframe acquisition modes
- Event channel
- Image chunk data
- Storable user sets

外形尺寸

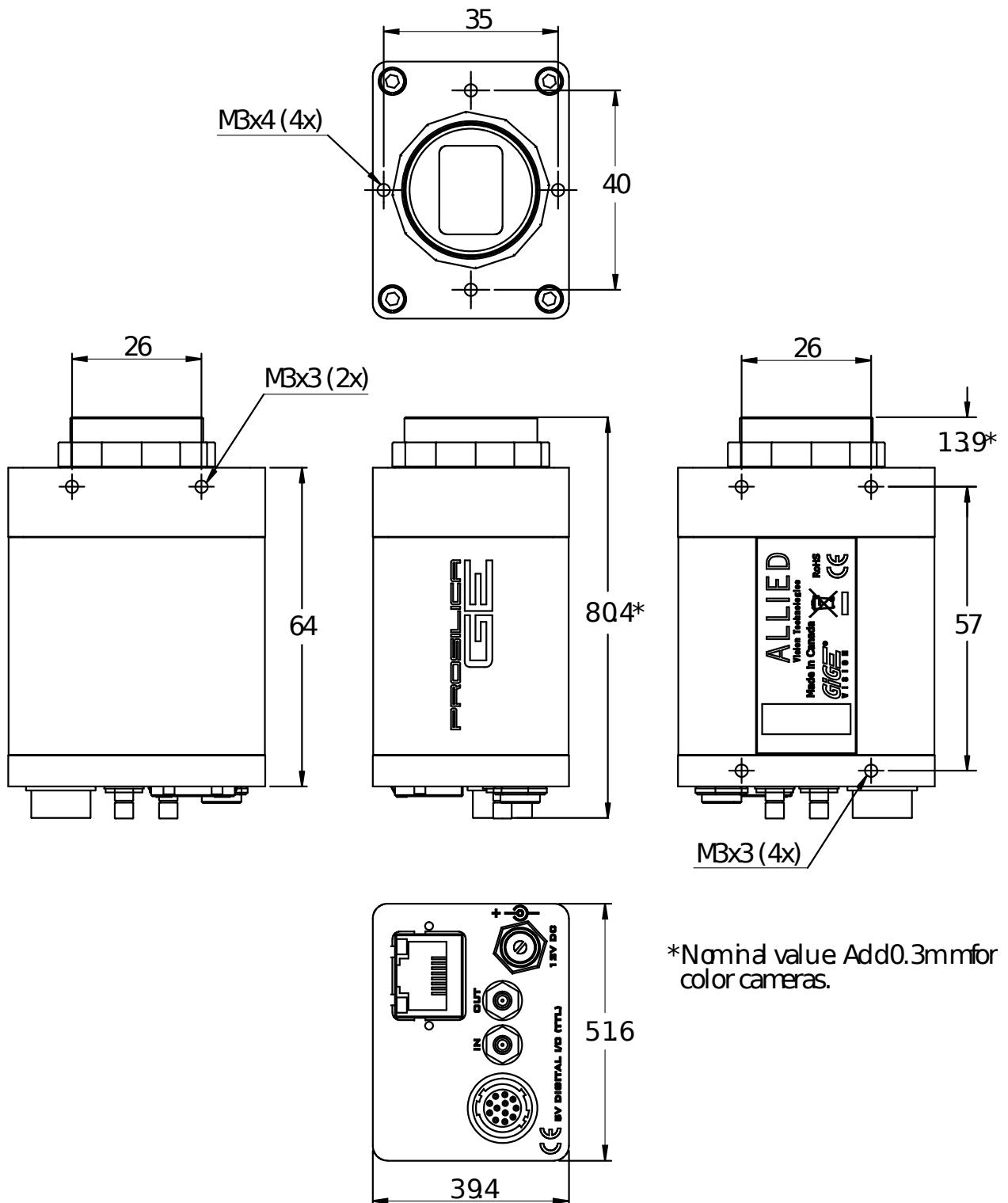

应用场景

Prosilica GE1650 is ideal for a wide range of applications including:

- Industrial inspection
- Machine vision
- LCD panel inspection
- Medical imaging
- Ophthalmology
- Aeronautical and aerospace
- Public security
- Surveillance
- Traffic imaging
- OEM applications