

# Prosilica GS

## 660



- Right-angle CCD camera with low height profile
- High frame rate
- Video-type auto iris
- Sony ICX618 sensor

### Landscape or portrait orientation

Right-angle CCD camera with Gigabit Ethernet interface

Prosilica GS 660 搭载 Sony ICX618 传感器，在 0.3 MP 分辨率下速度可达 119.0 帧/秒。

Prosilica GS cameras are periscope-type CCD cameras for industrial and microscopy applications. The compact GS-Series cameras have a Gigabit Ethernet interface (GigE Vision) that allows for very fast frame rates and long cable lengths.

- Compact size
- Very rugged
- Fast frame rates to 120 fps
- VGA to 5 Megapixels
- Landscape or portrait orientation
- Optional white medical housing
- Modular options available

## 性能参数

接口	IEEE 802.3 1000baseT
分辨率	659 (H) × 493 (V)
传感器	Sony ICX618
传感器类型	CCD Progressive
快门种类	GS (Global shutter)
传感器尺寸	Type 1/4
像元尺寸	5.6 μm × 5.6 μm
标准镜头接口	C-Mount
最大满帧帧率	119 fps
ADC	14 Bit
缓存 (RAM)	16 MByte

## 输出

Bit 位数	8-bit or 12-bit
黑白像素格式	Mono8, Mono12, Mono12Packed
YUV 彩色像素格式	YUV411Packed, YUV422Packed, YUV444Packed
RGB 彩色像素格式	RGB8Packed, BGR8Packed
原始像素格式	BayerRG8, BayerRG12, BayerGR12Packed

## 通用输入输出口 (GPIOs)

TTL I/Os	1 input, 1 output
光耦 I/Os	1 input, 1 output
RS232	1

## 工作条件/尺寸

工作温度	0 °C to +70 °C ambient (without condensation)
电源要求 (DC)	5 to 25 VDC
功耗	3 W at 12 VDC
重量	184 g
尺寸 (L × W × H in mm)	96 × 56 × 26 (including connectors)

## 量子转换效率

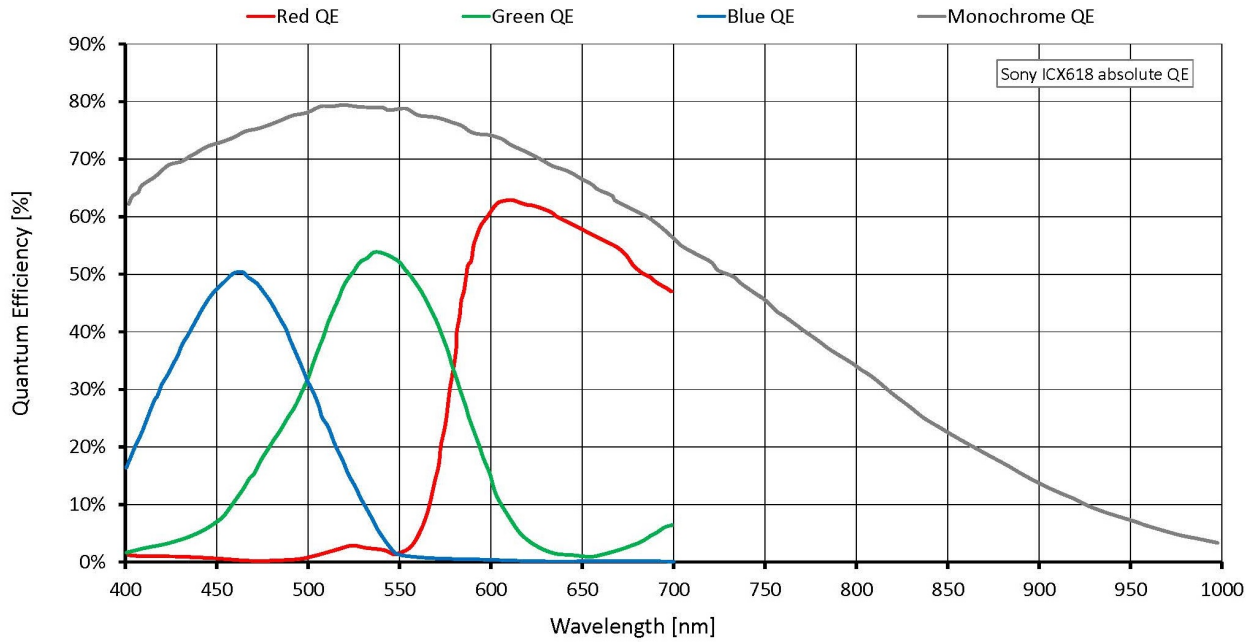

## 特性

Prosilica GS660 features include:

- Auto-iris (video type)
- Region of interest (ROI), DSP subregion (selectable ROI for auto features)
- Binning (Sum)
- Auto gain (manual gain control: 0 to 30 dB)
- Auto exposure (manual exposure controls: 10  $\mu$ s to 78.5 s)
- Auto white balance
- StreamBytesPerSecond (bandwidth control)
- Stream hold
- Sync out modes: Trigger ready, input, exposing, readout, imaging, strobe, GPO
- Global shutter (digital shutter)
- Recorder and Multiframe acquisition modes
- Event channel
- Image chunk data
- Storable user sets

## 外形尺寸

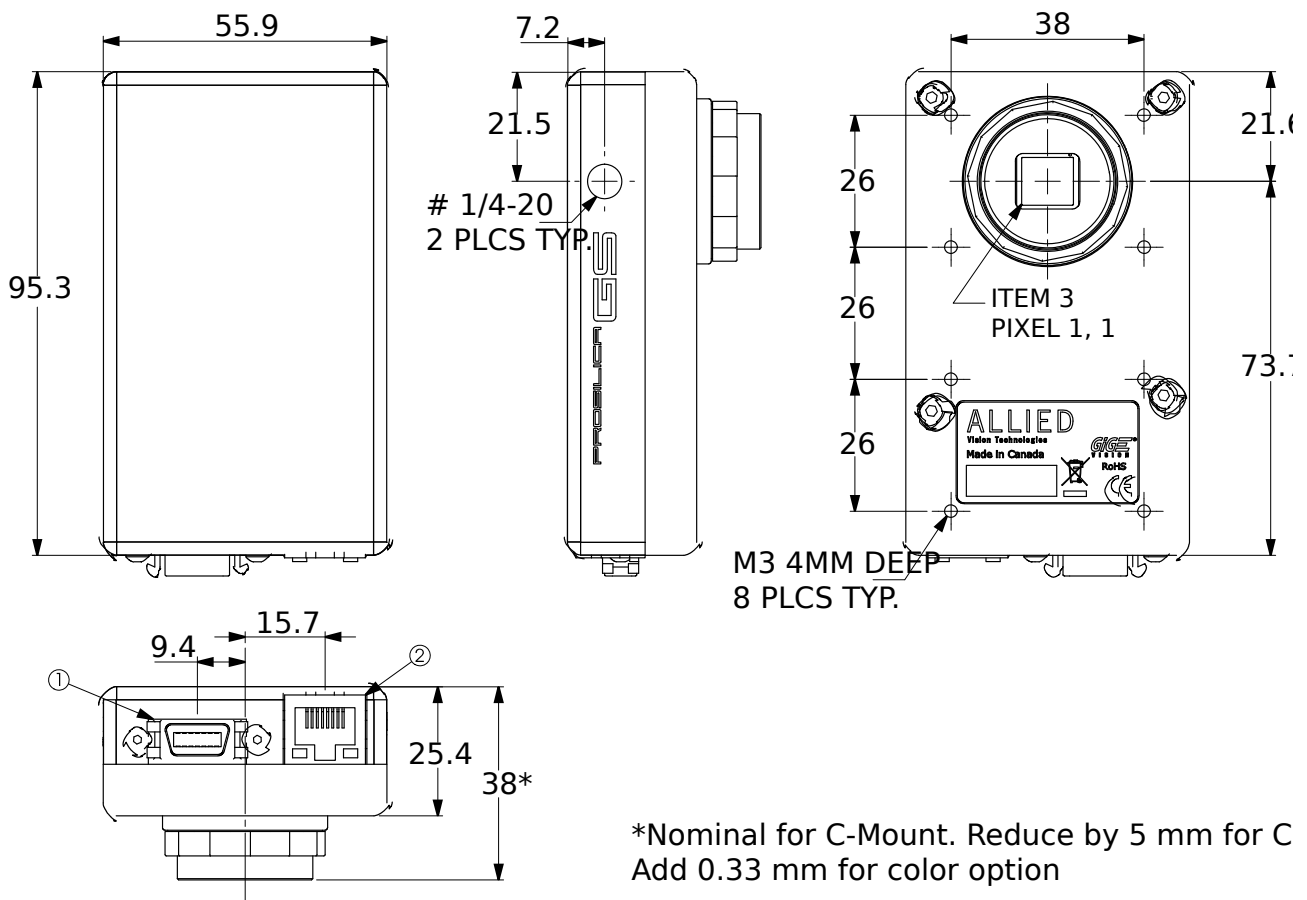

## 应用场景

Prosilica GS660 is ideal for a wide range of applications including:

- Machine vision
- Industrial inspection
- Public security
- Traffic monitoring
- Microscopy