

# Prosilica GX

## 1050



- 240 MBps with dual port LAG technology
- 3-axis motorized lens control
- High frame rate at full bit depth
- ON Semi KAI-01050 sensor

### Shift up to double speed

The fastest Gigabit Ethernet cameras in the world - 240MB/s

Prosilica GX 1050 搭载 ON Semi KAI-01050 传感器，在 1.0 MP 分辨率下速度可达 112.0 帧/秒。

Prosilica GX cameras are fast, compact machine vision cameras with Gigabit Ethernet interface (GigE Vision®). The GX-Series have two screw-captivated Gigabit Ethernet ports configured as a Link Aggregation Group (LAG) to provide a sustained maximum data rate of 240 MBytes per second. Prosilica GX can also work at half the bandwidth (120 MB/s) using a single cable.

- Very Fast - 240 MB/s
- 3-axis motorized lens control and video-type autoiris
- Single or dual Ethernet port operation
- 1 to 29 Megapixel
- Fast frame rates upto 112 fps
- OnSemi KAI or Sony quad-tap CCD sensors
- Modular options available

## 性能参数

接口	IEEE 802.3 1000baseT
分辨率	1024 (H) × 1024 (V)
传感器	ON Semi KAI-01050
传感器类型	CCD Progressive
快门种类	GS (Global shutter)
传感器尺寸	Type 1/2
像元尺寸	5.5 μm × 5.5 μm
标准镜头接口	C-Mount
最大满帧帧率	112 fps
ADC	14 Bit
缓存 (RAM)	128 MByte
<b>输出</b>	
Bit 位数	14-bit (monochrome)
黑白像素格式	Mono8, Mono12, Mono12Packed, Mono14
<b>通用输入输出口 (GPIOs)</b>	
光耦 I/Os	2 inputs, 4 outputs
RS232	1
<b>工作条件/尺寸</b>	
工作温度	0 °C to +50 °C ambient (without condensation)
电源要求 (DC)	10 to 24 VDC
功耗	5.4 W at 12 VDC (Single GigE Mode); 6.7 W at 12 VDC (Dual GigE Mode)
重量	269 g
尺寸 (L × W × H in mm)	107.2 × 53.3 × 33 (including connectors)

## 量子转换效率

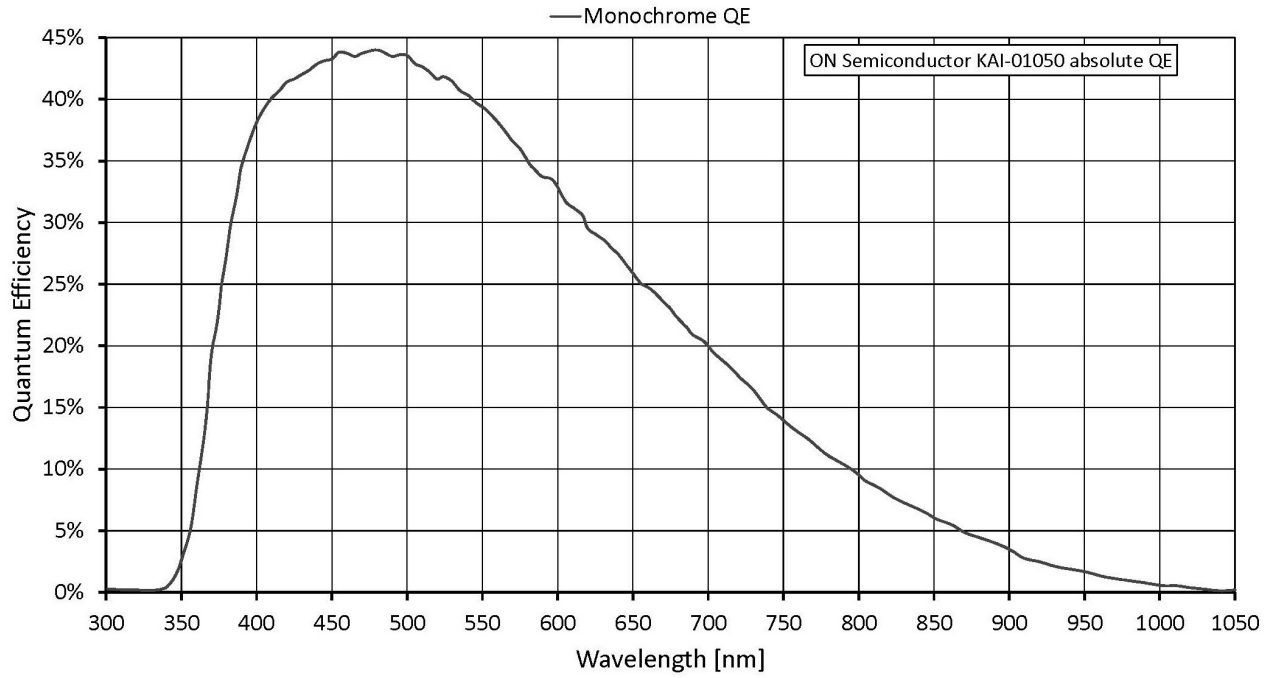

## 特性

### Image optimization features:

- Auto gain (manual gain control: 0 to 34 dB)
- Auto exposure (manual exposure controls: 10  $\mu$ s to 26.8 s)
- Binning (Sum)
- Region of interest (ROI), separate ROI for auto features

### Camera control features:

- 3-axis motorized lens control
- Auto-Iris (video type)
- Event channel
- Global shutter (digital shutter)
- Image chunk data
- Recorder and Multiframe acquisition modes
- RS232
- Storable user sets
- StreamBytesPerSecond (bandwidth control)
- Stream hold
- Sync out modes: Trigger ready, input, exposing, readout, imaging, strobe, GPO

## 外形尺寸

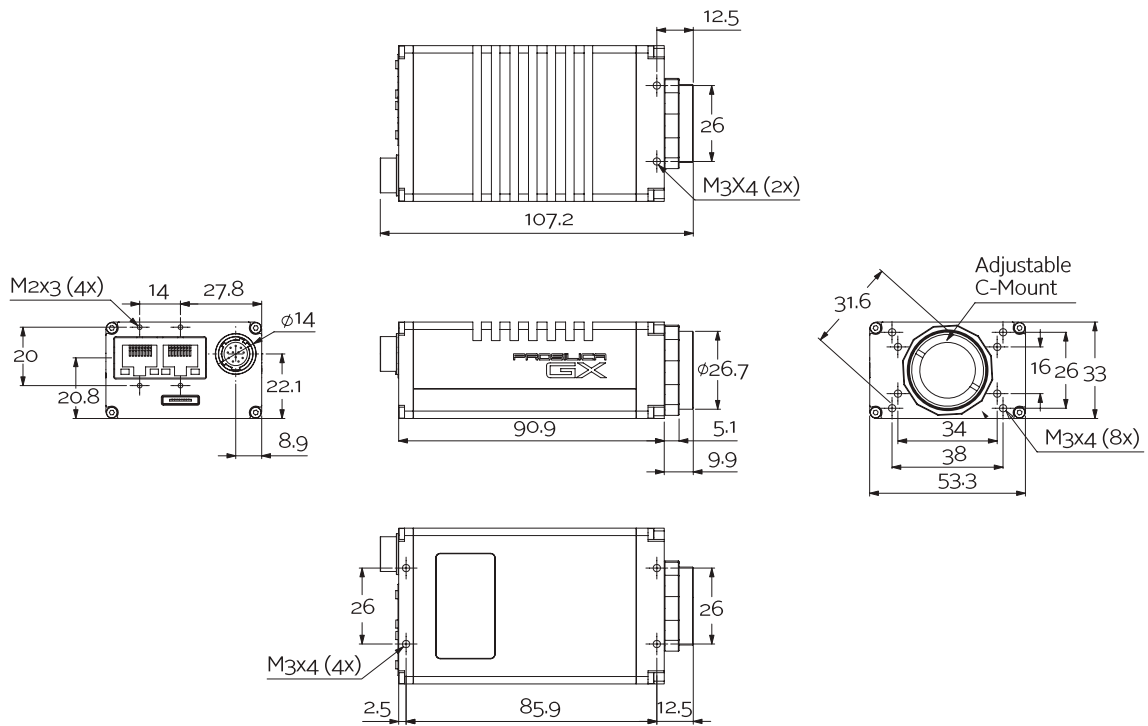

Prosilica GX1050 is ideal for a wide range of applications including:

- Industrial inspection
- Machine vision
- Medical imaging
- Public security
- Surveillance
- Traffic imaging
- OEM applications